



Workplace Wellness



LCD Monitor & Notebook Stand

Ergonomic Solutions



www.ergonoflex.com



LCD Monitor & Notebook Stand Ergonomic Solutions

Anyone working at a computer often adopts the same cramped posture. And moreover you always make the same movements. Which readily results in painful complaints such as cold hands, tingling fingers, a tennis elbow, and pain in the neck or shoulders. These are collectively known as “RSI”(Repetitive Strain Injury), the name for muscle and tendon complaints between the neck and fingertips caused by long-term use of the same muscles. We offers you ergonomic work area accessories that make work at the computer more comfortable and efficient.

Index

- * LCD Monitor Stand
(page 3 to page 8)
- * Notebook Stand
(page 9 to page 15)



LCD & Notebook
Applications Stand



Workplace Wellness

www.ergonoflex.com

Product Data Sheet

LCD Monitor Stand

Monitor/Keyboard HF
150 mm

300 x 300 x 150 mm

Color Clear



LCD Monitor/Keyboard Stand HF 150 mm

Anyone working at a computer often adopts the same cramped posture. And moreover you always make the same movements. Which readily results in painful complaints such as cold hands, tingling fingers, a tennis elbow, and pain in the neck or shoulders. These are collectively known as “RSI”(Repetitive Strain Injury), the name for muscle and tendon complaints between the neck and fingertips caused by long-term use of the same muscles. We offers you ergonomic work area accessories that make work at the computer more comfortable and efficient.

- Optimises workspace
- Space for the keyboard
- Dimensions : 300x300x150 mm
- Max load. : 40 kgs
- Fixed height
- Color : clear

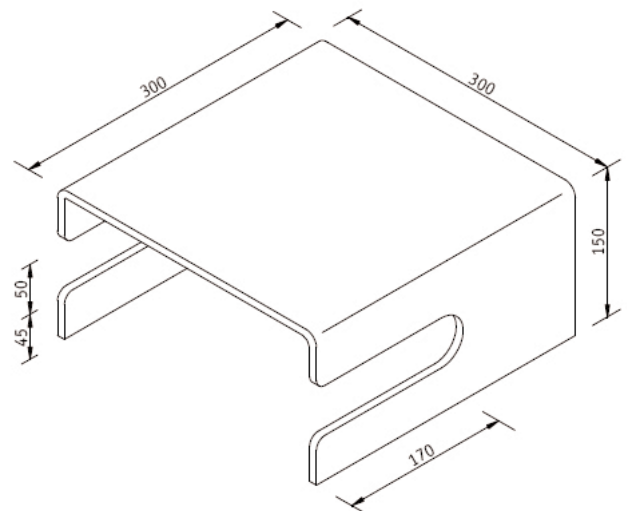

Workplace Wellness

Part Number
EGF 44100

www.ergonoflex.com



Product Data Sheet

LCD Monitor Stand

Monitor/keyboard/Holder

300 x 300 x 150 mm

Color Clear

Workplace Wellness

Monitor/Keyboard/Holder Stand

Anyone working at a computer often adopts the same cramped posture. And moreover you always make the same movements. Which readily results in painful complaints such as cold hands, tingling fingers, a tennis elbow, and pain in the neck or shoulders. These are collectively known as “RSI”(Repetitive Strain Injury), the name for muscle and tendon complaints between the neck and fingertips caused by long-term use of the same muscles. We offers you ergonomic work area accessories that make work at the computer more comfortable and efficient.

- Optimises workspace
- Space for the keyboard
- Convenient for screens from 17 up to 19 “
- Retractable A3 copy holder
- Dimensions : 300x300x150 mm
- Max load. : 40 kgs
- Fixed height
- Color : clear

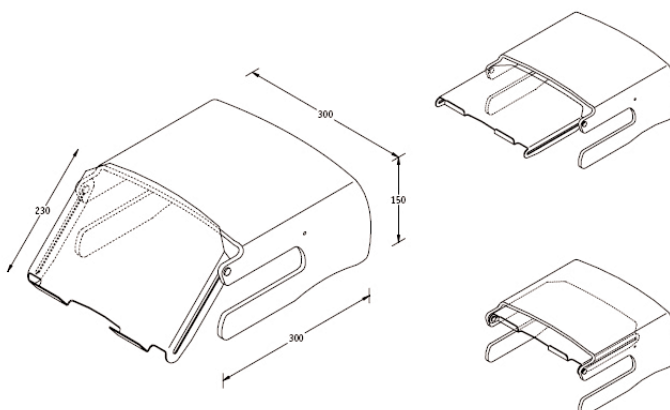

Part Number
EGF 44200

www.ergonoflex.com

Product Data Sheet

LCD Monitor Stand

Multi Use

512 x 310 x 100 mm

Color Clear



LCD Monitor Multi Use Stand

Anyone working at a computer often adopts the same cramped posture. And moreover you always make the same movements. Which readily results in painful complaints such as cold hands, tingling fingers, a tennis elbow, and pain in the neck or shoulders. These are collectively known as “RSI”(Repetitive Strain Injury), the name for muscle and tendon complaints between the neck and fingertips caused by long-term use of the same muscles. We offers you ergonomic work area accessories that make work at the computer more comfortable and efficient.

- For an optimisation of the work space
- Dimensions : 512x310x100 mm
- Max load. : 40 kgs
- Fixed height
- Color : clear

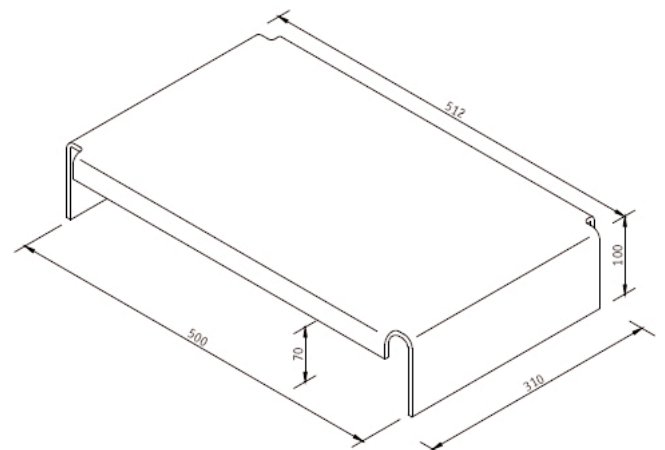

Workplace Wellness

Part Number
EGF 44900

www.ergonoflex.com



Product Data Sheet

LCD Monitor Stand

Monitor/Keyboard/
Holder HA

310 x 275 x 105 mm

Color Clear

LCD Monitor/Keyboard/Holder HA Stand

Anyone working at a computer often adopts the same cramped posture. And moreover you always make the same movements. Which readily results in painful complaints such as cold hands, tingling fingers, a tennis elbow, and pain in the neck or shoulders. These are collectively known as “RSI”(Repetitive Strain Injury), the name for muscle and tendon complaints between the neck and fingertips caused by long-term use of the same muscles. We offers you ergonomic work area accessories that make work at the computer more comfortable and efficient.

- For an optimization of the workspace
- Filing space for the keyboard
- Is appropriate for screens from 17 to 19 “
- dimension: 310x275x105 mm
- Max load. : 15 kgs
- Height adjustable 5 levels
- Color : clear

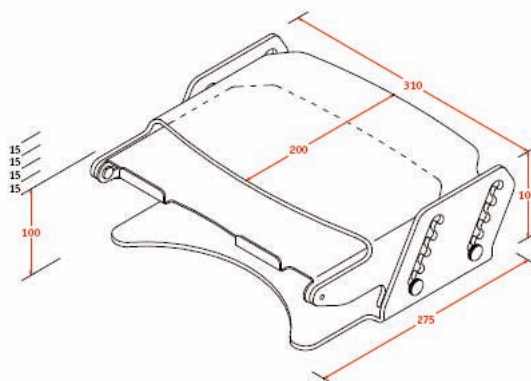

Workplace Wellness

Part Number
EGF 49570

www.ergonoflex.com

Product Data Sheet

LCD Monitor Stand

Monitor/keyboard FH

270 x 255 x 110 mm

Color Clear

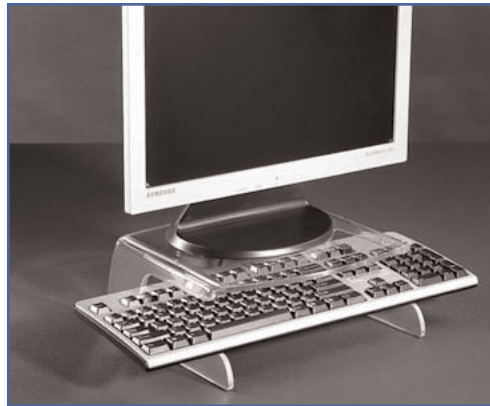

Monitor/Keyboard FH Stand

Anyone working at a computer often adopts the same cramped posture. And moreover you always make the same movements. Which readily results in painful complaints such as cold hands, tingling fingers, a tennis elbow, and pain in the neck or shoulders. These are collectively known as “RSI”(Repetitive Strain Injury), the name for muscle and tendon complaints between the neck and fingertips caused by long-term use of the same muscles. We offers you ergonomic work area accessories that make work at the computer more comfortable and efficient.

- For a more comfortable posture
- Convenient for LCD screens up to 20”
- Storage space for your keyboard
- Dimensions : 270x255x110 mm
- Max load. : 15 kgs
- Fixed height
- Color : clear

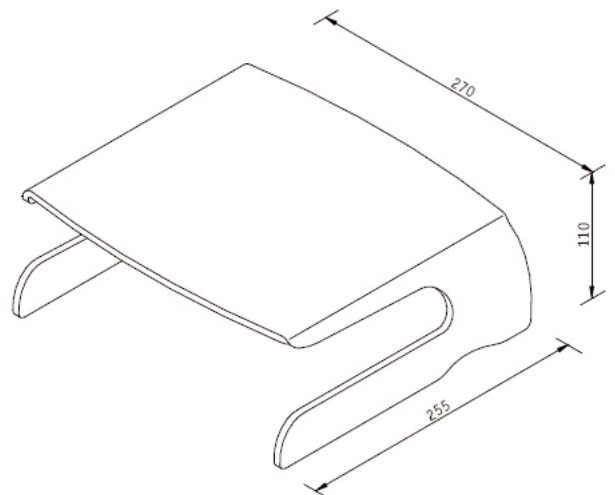

Workplace Wellness

Part Number
EGF 44550

www.ergonoflex.com



Product Data Sheet

LCD Monitor Stand

Monitor/Keyboard HA
512 x 310 x 100 mm

Color Clear

LCD Monitor/Keyboard HA Stand

Anyone working at a computer often adopts the same cramped posture. And moreover you always make the same movements. Which readily results in painful complaints such as cold hands, tingling fingers, a tennis elbow, and pain in the neck or shoulders. These are collectively known as “RSI”(Repetitive Strain Injury), the name for muscle and tendon complaints between the neck and fingertips caused by long-term use of the same muscles. We offers you ergonomic work area accessories that make work at the computer more comfortable and efficient.

- For a more comfortable posture
- Convenient for LCD screens up to 20”
- Storage space for your keyboard
- Dimensions : 320x256x107 mm
- Max load. : 15 kgs
- Height adjustable 5 levels
- Color : clear

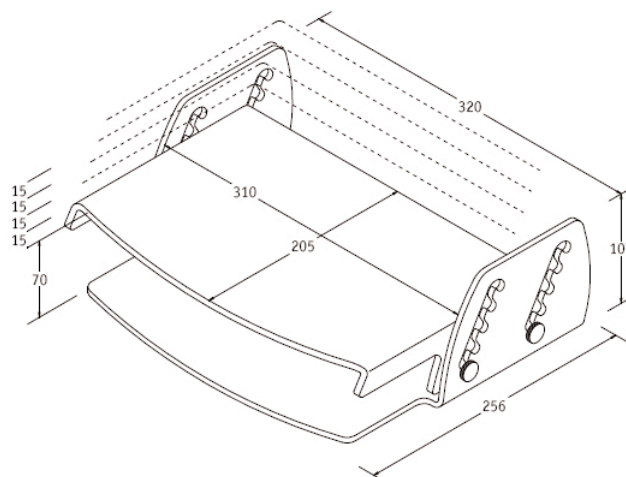

Workplace Wellness

Part Number
EGF 49550

www.ergonoflex.com

Product Data Sheet



Notebook Stand

Ergonote Basic

300 x 275 x 120 mm

Color Clear

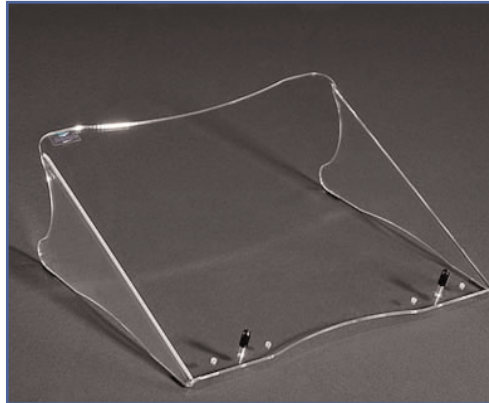

Ergonote Basic

Anyone working at a computer often adopts the same cramped posture. And moreover you always make the same movements. Which readily results in painful complaints such as cold hands, tingling fingers, a tennis elbow, and pain in the neck or shoulders. These are collectively known as “RSI”(Repetitive Strain Injury), the name for muscle and tendon complaints between the neck and fingertips caused by long-term use of the same muscles. We offers you ergonomic work area accessories that make work at the computer more comfortable and efficient.

- For a more comfortable posture while typing
- Convenient for notebooks with a 15” screen
- The use of a additional keyboard and mouse is necessary
- Dimensions : 300x275x120 mm
- Fixed height
- Color : clear

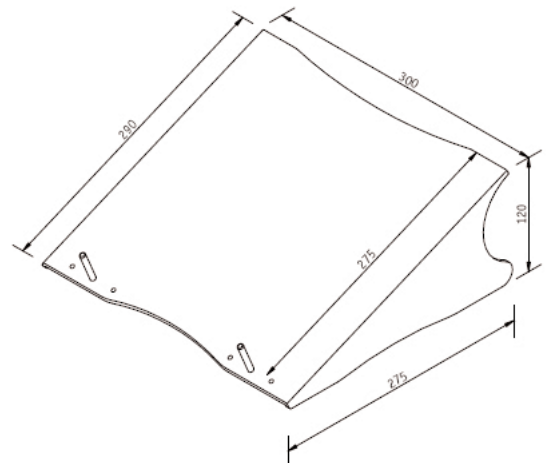

Workplace Wellness

Part Number
EGF 44450

www.ergonoflex.com



Product Data Sheet

Notebook Stand

Notebook Center

350 x 300 x 150 mm

Color Clear

Notebook Center

Anyone working at a computer often adopts the same cramped posture. And moreover you always make the same movements. Which readily results in painful complaints such as cold hands, tingling fingers, a tennis elbow, and pain in the neck or shoulders. These are collectively known as “RSI”(Repetitive Strain Injury), the name for muscle and tendon complaints between the neck and fingertips caused by long-term use of the same muscles. We offers you ergonomic work area accessories that make work at the computer more comfortable and efficient.

- For a more comfortable posture
- Convenient for LCD screens up to 20”
- Storage space for your keyboard
- Dimensions : 350x300x150 mm
- Max load. : 40 kgs
- Fixed height
- Color : clear

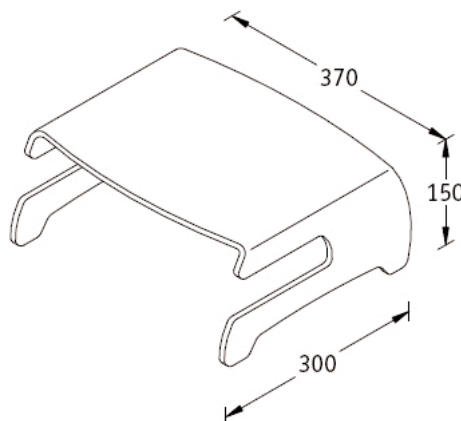

Workplace Wellness

Part Number
EGF 44650

www.ergonoflex.com

Product Data Sheet



Notebook Stand

Notebook Center XL

420 x 300 x 150 mm

Color Clear



Notebook Center XL

Anyone working at a computer often adopts the same cramped posture. And moreover you always make the same movements. Which readily results in painful complaints such as cold hands, tingling fingers, a tennis elbow, and pain in the neck or shoulders. These are collectively known as “RSI”(Repetitive Strain Injury), the name for muscle and tendon complaints between the neck and fingertips caused by long-term use of the same muscles. We offers you ergonomic work area accessories that make work at the computer more comfortable and efficient.

- For a more comfortable posture
- Convenient for LCD screens up to 20”
- Storage space for your keyboard
- Dimensions : 420 x 300 x 150 mm
- Max load. : 40 kgs
- Fixed height
- Color : clear

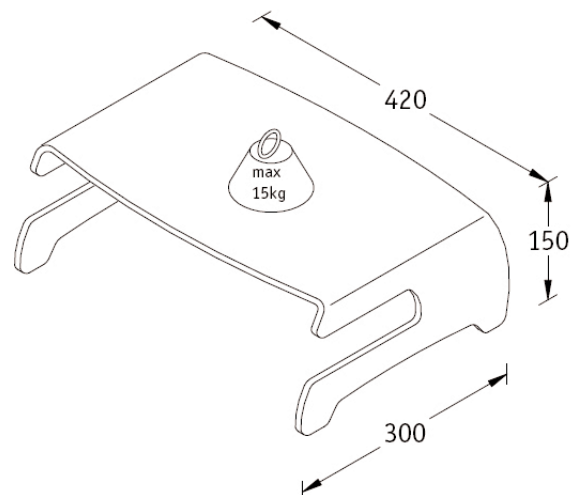

Workplace Wellness

Part Number
EGF 44660

www.ergonoflex.com

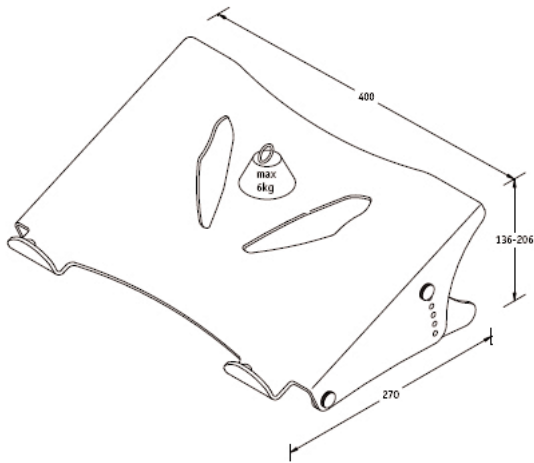

Product Data Sheet

Notebook Stand

Ergo Note XL

400 x 270 x 136-206 mm

Color Clear

Ergo Note

Anyone working at a computer often adopts the same cramped posture. And moreover you always make the same movements. Which readily results in painful complaints such as cold hands, tingling fingers, a tennis elbow, and pain in the neck or shoulders. These are collectively known as “RSI”(Repetitive Strain Injury), the name for muscle and tendon complaints between the neck and fingertips caused by long-term use of the same muscles. We offers you ergonomic work area accessories that make work at the computer more comfortable and efficient.

- For a more comfortable posture
- Suitable for larger Notebooks up to 17”
- Enables users to place their Notebooks at an ergonomic height
- Helps to create a better working posture
- Use with additional keyboard and mouse
- Dimensions : 420x270x136-206 mm 6 positions
- Height adjustable from 136-206 mm (6 positions)
- Color : clear

Workplace Wellness

Part Number
EGF 49460

www.ergonoflex.com

Product Data Sheet



Notebook Stand

Ergo Note

350 x 270 x 136-206 mm

Color Clear



Ergo Note

Anyone working at a computer often adopts the same cramped posture. And moreover you always make the same movements. Which readily results in painful complaints such as cold hands, tingling fingers, a tennis elbow, and pain in the neck or shoulders. These are collectively known as “RSI”(Repetitive Strain Injury), the name for muscle and tendon complaints between the neck and fingertips caused by long-term use of the same muscles. We offers you ergonomic work area accessories that make work at the computer more comfortable and efficient.

- For a more comfortable posture
- Convenient for notebooks with a screen from 15 up to 17 “
- The use of a additionnal keyboard and mouse is necessary
- Dimensions : 350x270x136-206 mm
- Height adjustable on 6 levels
- Color : clear

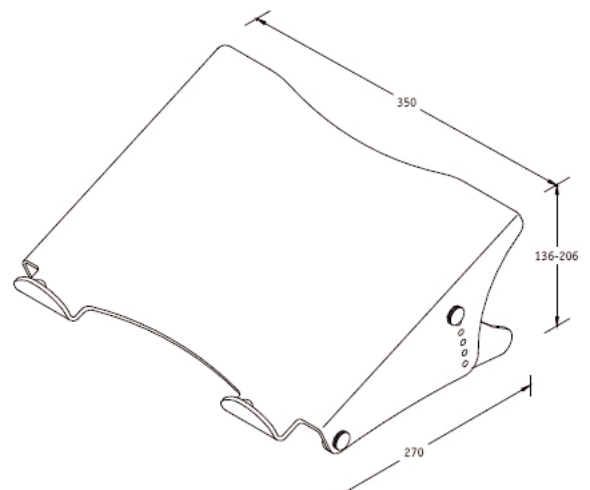

Workplace Wellness

Part Number
EGF 49450

www.ergonoflex.com

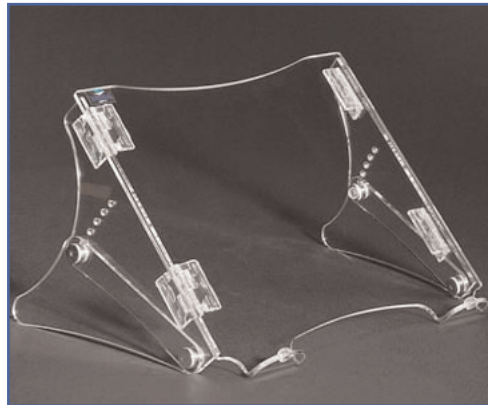

Ergo Note Compact

Anyone working at a computer often adopts the same cramped posture. And moreover you always make the same movements. Which readily results in painful complaints such as cold hands, tingling fingers, a tennis elbow, and pain in the neck or shoulders. These are collectively known as “RSI”(Repetitive Strain Injury), the name for muscle and tendon complaints between the neck and fingertips caused by long-term use of the same muscles. We offers you ergonomic work area accessories that make work at the computer more comfortable and efficient.

- For a more comfortable posture
- Foldable
- Convenient for notebook up to 15 “
- The use of a additionnal keyboard and mouse is necessary
- Dimensions : 300x270x136-206 mm
- Height adjustable with 6 levels
- Color : clear

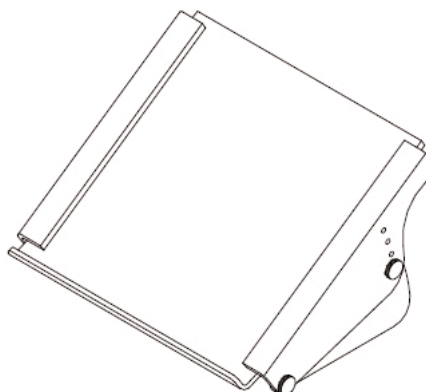

Product Data Sheet

Notebook Stand

Ergo Note Compact

300 x 270 x 136-206 mm

Color Clear

Workplace Wellness

Part Number
EGF 49550

www.ergonoflex.com



Workplace Wellness



LCD Monitor & Notebook Stand

Ergonomic Solutions



www.ergonoflex.com